

The background is a dark blue field filled with various shades of blue gears of different sizes, some overlapping. On the left side, there is a vertical strip with a colorful, textured pattern of gears in shades of orange, yellow, and brown.

How It Works

Diesel Locomotive
Air Breaking
Dynamic Breaking

Power Generation

How Diesel Locomotives Work

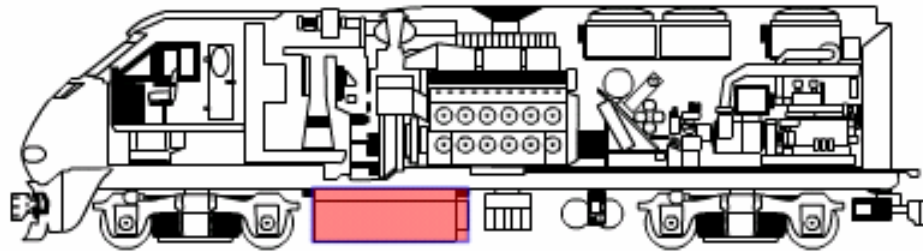

Engine Turbocharger

Main Engine

Main Generator

Cab

Head-end power unit

Fuel Tank

Batteries

Cooling Fans/Radiators

Trucks

Control Stand

Coupler

Filters

Cab Seat

Air Compressor

Dynamic Brake Grid

Dynamic Brake Fan

Compressed Air Tank



© 2001 HowStuffWorks

- ★ Diesel gas is the energy source

© 2001 HowStuffWorks

Power Generation

How Diesel Locomotives Work

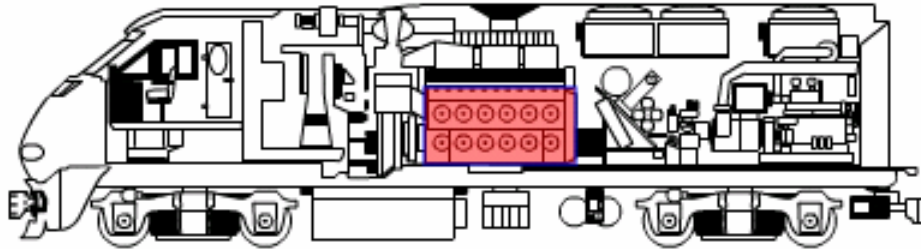

Engine Turbocharger

Main Engine

Main Generator

Cab

Head-end power unit

Fuel Tank

Batteries

Cooling Fans/Radiators

Trucks

Control Stand

Coupler

Filters

Cab Seat

Air Compressor

Dynamic Brake Grid

Dynamic Brake Fan

Compressed Air Tank



- ☀ Diesel gas is the energy source
- ☀ Gas fuels the engine

Power Generation

How Diesel Locomotives Work

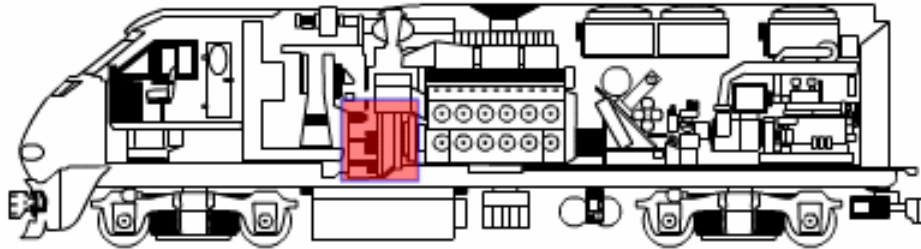

Engine Turbocharger

Main Engine

Main Generator

Cab

Head-end power unit

Fuel Tank

Batteries

Cooling Fans/Radiators

Trucks

Control Stand

Coupler

Filters

Cab Seat

Air Compressor

Dynamic Brake Grid

Dynamic Brake Fan

Compressed Air Tank

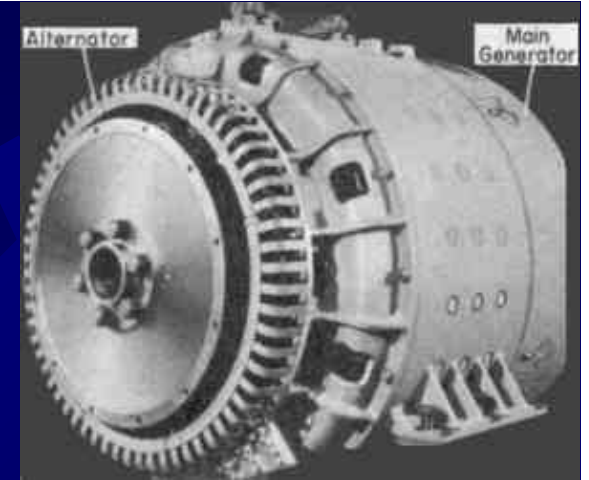

- ★ Diesel gas is the energy source
- ★ Gas fuels the engine
- ★ The engine turns the generator
- ★ The generator produces electricity

Power Generation

How Diesel Locomotives Work

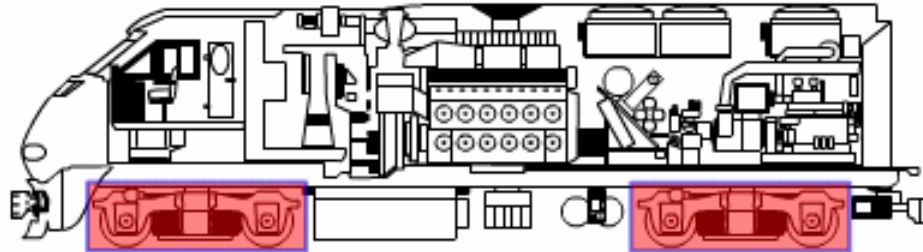

Engine Turbocharger

Main Engine

Main Generator

Cab

Head-end power unit

Fuel Tank

Batteries

Cooling Fans/Radiators

Trucks

Control Stand

Coupler

Filters

Cab Seat

Air Compressor

Dynamic Brake Grid

Dynamic Brake Fan

Compressed Air Tank



- ☀ Diesel gas is the energy source
- ☀ Gas fuels the engine
- ☀ The engine turns the generator
- ☀ The generator produces electricity
- ☀ The electricity turns the motors in the trucks

Air Breaking



How Diesel Locomotives Work

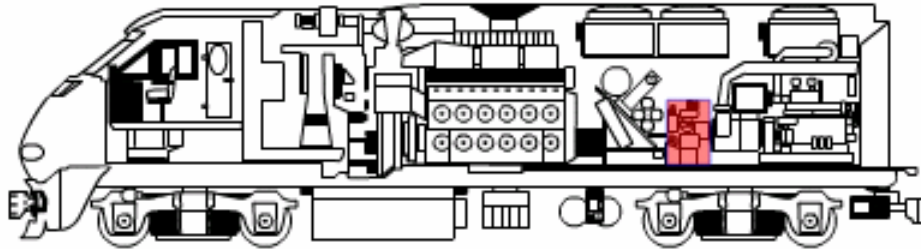

Engine Turbocharger

Main Engine

Main Generator

Cab

Head-end power unit

Fuel Tank

Batteries

Cooling Fans/Radiators

Trucks

Control Stand

Coupler

Filters

Cab Seat

Air Compressor

Dynamic Brake Grid

Dynamic Brake Fan

Compressed Air Tank

- Engine drives an air compressor

Air Breaking

How Diesel Locomotives Work

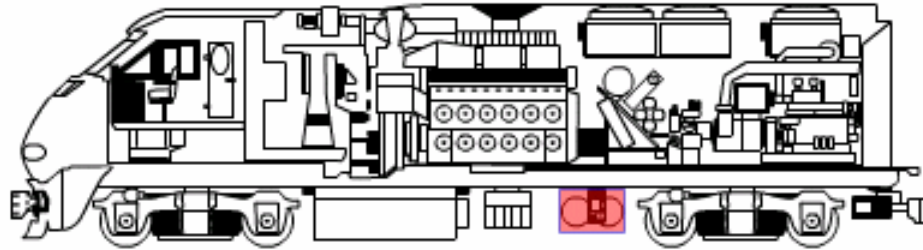

Engine Turbocharger
Main Engine
Main Generator
Cab
Head-end power unit
Fuel Tank
Batteries
Cooling Fans/Radiators
Trucks
Control Stand

Coupler
Filters
Cab Seat
Air Compressor
Dynamic Brake Grid
Dynamic Brake Fan
Compressed Air Tank

© 2001 HowStuffWorks



© 2001 HowStuffWorks

- ✦ Engine drives an air compressor
- ✦ Air compressor fills an air tank
- ✦ Air tank supplies pressure to every car in the train
- ✦ Air pressure keeps break shoes from touching wheels

Air Breaking

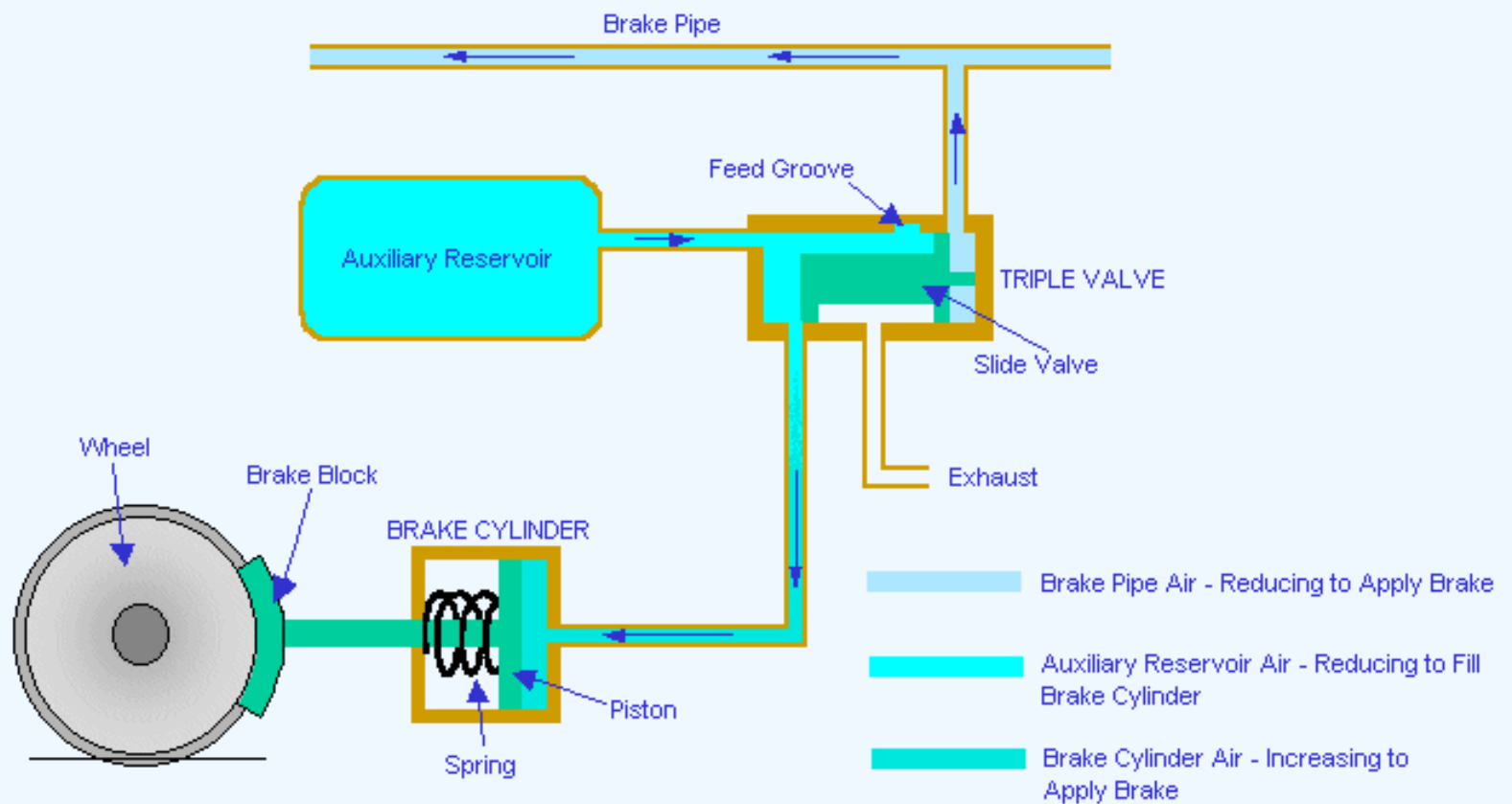

Schematic Diagram of Air Brake System on Vehicle in Application Position

Dynamic Breaking

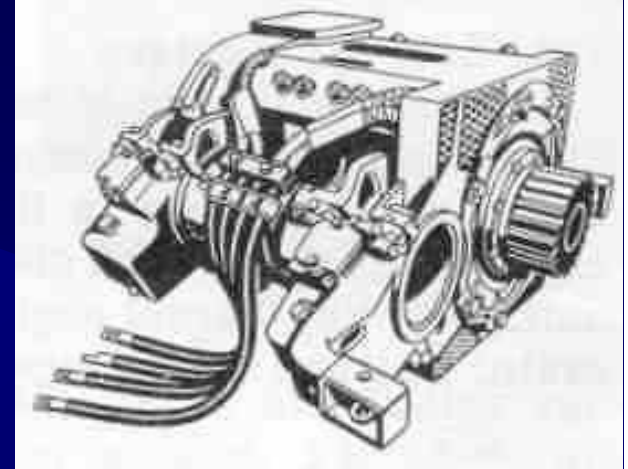

How Diesel Locomotives Work

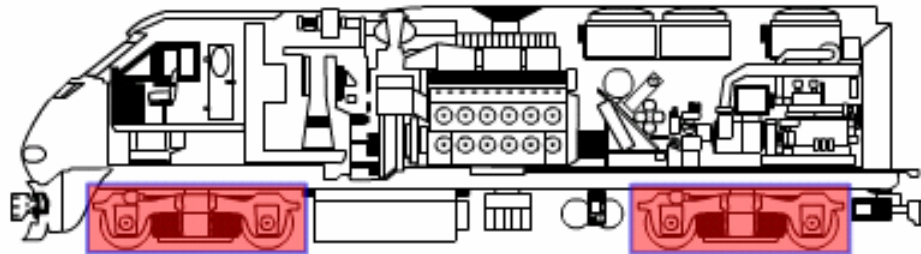

Engine Turbocharger

Main Engine

Main Generator

Cab

Head-end power unit

Fuel Tank

Batteries

Cooling Fans/Radiators

Trucks

Control Stand

Coupler

Filters

Cab Seat

Air Compressor

Dynamic Brake Grid

Dynamic Brake Fan

Compressed Air Tank

- ✦ Electric is no longer routed to motors
- ✦ Traction motors act like electrical generators

Dynamic Breaking

How Diesel Locomotives Work

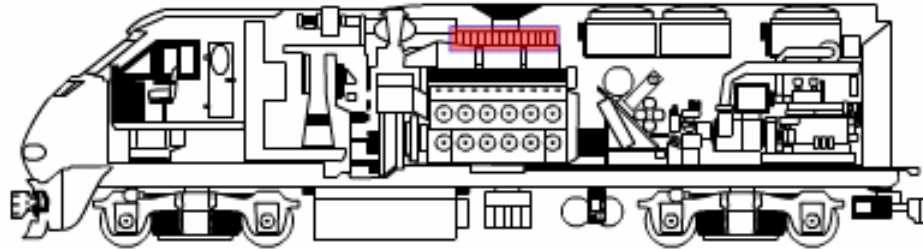

Engine Turbocharger
Main Engine
Main Generator
Cab
Head-end power unit
Fuel Tank
Batteries
Cooling Fans/Radiators
Trucks
Control Stand

Coupler
Filters
Cab Seat
Air Compressor
Dynamic Brake Grid
Dynamic Brake Fan
Compressed Air Tank

© 2001 HowStuffWorks

- ✦ Electric is no longer routed to motors
- ✦ Traction motors act like electrical generators
- ✦ Electricity turned to heat in the brake grid

Dynamic Breaking

How Diesel Locomotives Work

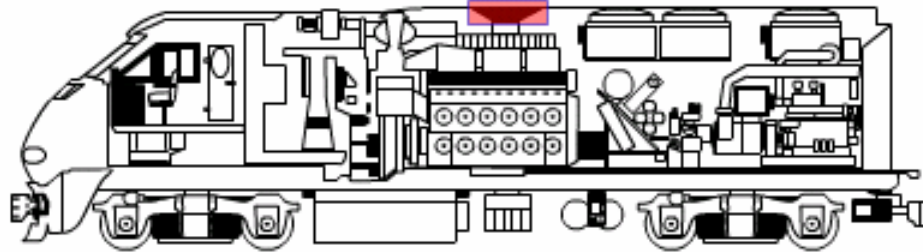

Engine Turbocharger
Main Engine
Main Generator
Cab
Head-end power unit
Fuel Tank
Batteries
Cooling Fans/Radiators
Trucks
Control Stand

Coupler
Filters
Cab Seat
Air Compressor
Dynamic Brake Grid
Dynamic Brake Fan
Compressed Air Tank

© 2001 HowStuffWorks

- ✦ Electric is no longer routed to motors
- ✦ Traction motors act like electrical generators
- ✦ Electricity turned to heat in the brake grid
- ✦ Fan removes heat from locomotive

Suspension

How Diesel Locomotives Work

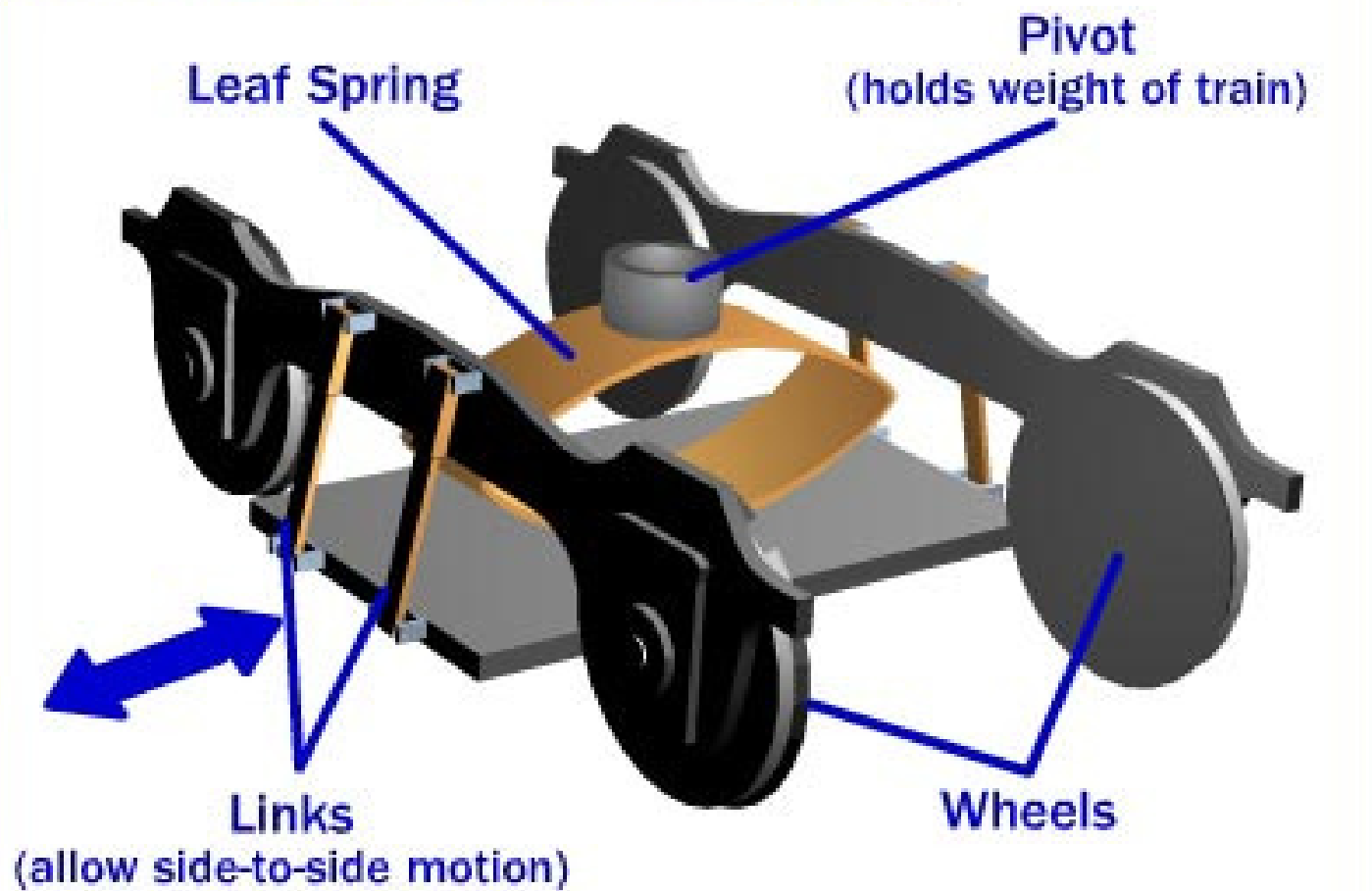

Steering

Radial Steering prevents track wear

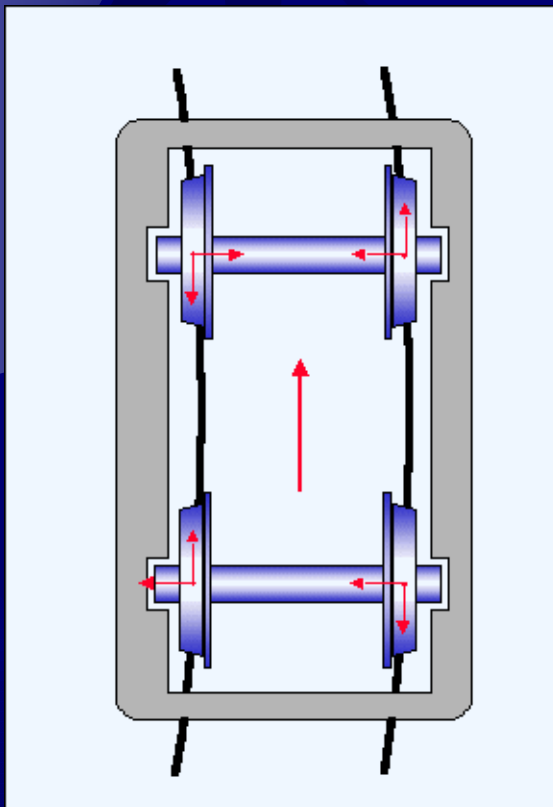

Typical Trucks

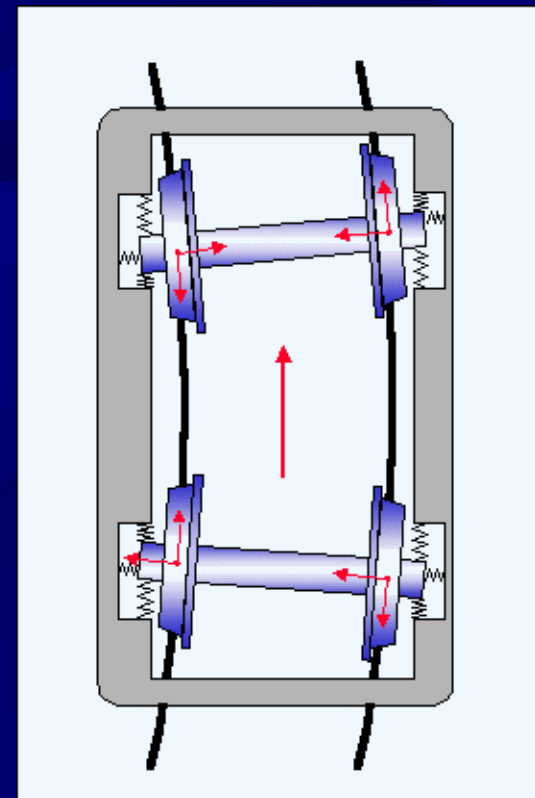

Radial Steering Trucks