

ASSEMBLY INSTRUCTIONS:



42'

Single & Triple Dome

TANK CARS

REVISED:
L. MUNSON
4-73

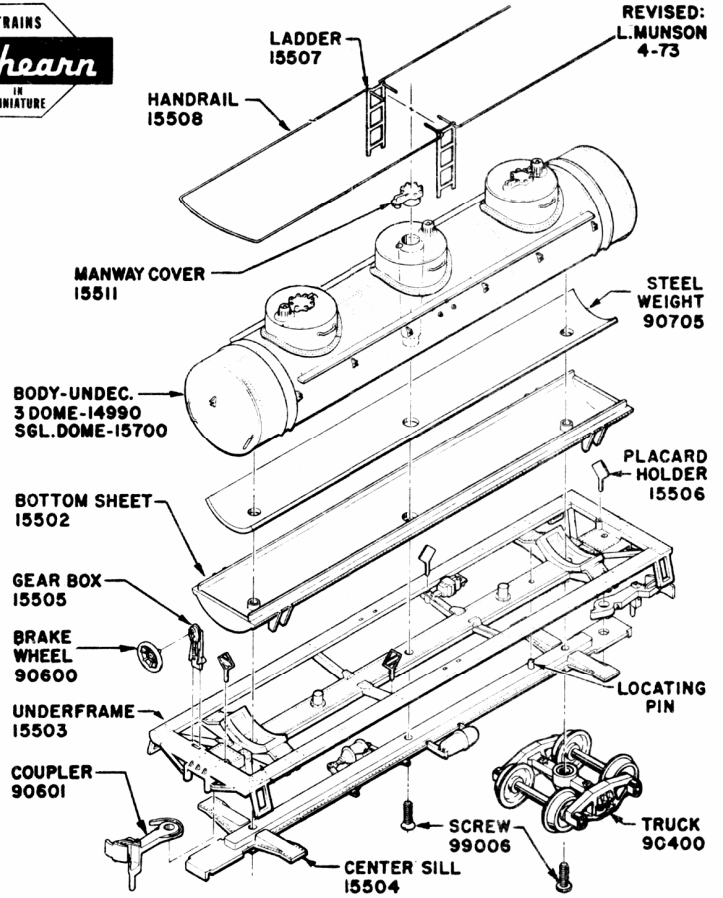

PART	NUMBER
BODY-3 DOME-UNDECORATED	14990
BODY-SINGLE DOME-UNDECORATED	15700
BOTTOM SHEET	15502
UNDERFRAME	15503
CENTER SILL	15504
BRAKE GEAR BOX	15505
PLACARD HOLDER	DZ. 15506
LADDER	DZ. 15507
HANDRAIL	EA. 15508
MANWAY COVER	15511
BETTENDORF TRUCK	PR. 90400
BRAKE WHEEL	DZ. 90600
COUPLER	PR. 90601
COVER PLATE	DZ. 90602
STEEL WEIGHT	90705
RH SCREW 2-56 X 1/2"	DZ. 99006

Tools needed to assemble this kit:	Small Screw Driver	NMRA wheel & track gage
	Needle-nose pliers	Paint (optional)
	Nail file (Coarse and fine sandpaper)	#2-56 thread tap with pin vise (optional)
	Wood tooth pick (for applying Cyanocrylate glue)	

Adhesives needed to assemble kit:	Liquid cement for styrene -- for joining plastic to plastic
	Cyanocrylate (super glue) -- for joining metal to plastic

CAUTION: Avoid using excess glue. Most joints fit tightly without the need for gluing.

1. Open envelope containing small parts. Set aside for later.
2. Install steel weight in upper tank shell section. You may put a small amount of Cyanocrylate glue around the center post, where the hole in the weight will be seated, to make sure the weight is firmly secured within the tank shell.
3. Snap lower tank shell section in place - no need to glue this joint, as a screw will be installed into the center post later.
4. (Optional) Run a #2-56 tap through the two holes in the underframe, where truck screws will be secured. This step will provide for easier installation of the truck mounting screws in a later step.
5. Install the brake wheel in the gearbox. The wheel goes into the side with the protruding housing, the flat side. This is a tight fit, and shouldn't require glue. Set aside for installation in the underframe later.
6. Install couplers into the coupler boxes in the underframe, and snap the center sill into place. "Kadee" couplers may be substituted for the X2F style (Horn-hook) couplers provided with the kit. The center sill only fits one way, as there is a locating pin to prevent incorrect assembly. Snap each end of the center sill down into the proper position to retain the couplers. No glue is needed for this step.

7. Install the four metal placard holders in the four small holes located on each We of the underframe. This is the most difficult step, as the placard holders are rectangular in cross-section, and don't fit well into the small round holes provided. It may help to file the lower edges of the placard holders to more of a round cross section, which will be easier to force into the holes. Be careful not to damage the underframe while trying to install these parts. Use needle-nose pliers to push the placard holders into the holes, or leave them off if this is too much of a challenge for you. Note: It is nearly impossible to install these parts if you have already installed the tank assembly to the underframe.
8. Install the underframe assembly to the tank assembly. Make sure the tank seats securely on the underframe. No glue is needed. Run the longer screw up through the center hole in the underframe, and into the center post in the bottom of the tank assembly. Don't over tighten.
9. Install the two tank handrails, and the two ladders as follows: Check the tank handrails; to see if the ends are bent at a 90-degree (right) angle. If they are not bent at a 90-degree angle, they will not fit properly into the holes in the tank sides. The handrails can be bent using needle-nose pliers. Be careful not to bend them too much, as the wire ends can work harden and break off. Also check the holes in the tank - they may not be drilled all the way through. I used a 0.024-inch diameter drill to drill these holes through. If you don't have one, try to push the end of one of the handrails through the holes. Slip a ladder into the two small slots in the underframe on each side of the tank. Carefully spread the sides of one handrail to slip it onto the tank from the end. Install one bent end of the handrail through the hole in the ladder, and push into the hole in the tank until it seats. Make sure the handrail is aligned with the centers of all the small brackets on both sides and the end of the tank. Now insert the other bent end of the handrail through the hole in the other ladder, and push into the hole in the tank until it is also seated. Repeat the process for the other handrail on the other end of the tank. No glue should be necessary, as the wires should fit tightly. If you wish, you can turn the tank/underframe over, and apply small amounts of Cyanocrylate glue to the underside of the ladder ends, where they protrude through the bottom of the underframe.
10. Check the positioning of the wheel sets, using the NMRA wheel and track gage. Adjust wheels on axles, if necessary, to ensure that the wheel sets are in gage.
11. While spreading the truck side frames with your fingers, carefully insert each wheel and axle assembly, being careful not to groove the truck side frames with the sharp points of the axles.
12. Install each assembled truck assembly to the underframe using the screws provided. Be careful not to over tighten the screws. The trucks should be able to rotate freely. For better stability, leave one screw about a full turn loose, while the other screw is tight enough to allow its truck to rotate, but not wobble. This will provide a three-point suspension for your car, which is very stable.
13. Install the brake wheel and its stand into the slot in the one end of the frame end platform. You can use either styrene cement or Cyanocrylate glue for this joint. This is one location where the parts do not fit tightly, so glue will be needed if you don't want to lose your car's brake wheel.

Congratulations, your single dome tank car is now complete.

For added realism, your car can be weathered, using chalks, "dry brushing" technique with paints, or a dilute wash of India ink and water, to make it appear old or dirty. A coat of flat lacquer, such as Testor's Dull Cote, will take away the shine of the plastic, and give your car's finish a more realistic appearance. Be sure if you paint, to do it in a properly ventilated area (or outside in mild weather).